



EvolutionROTM1000
High-Flow Reverse Osmosis System

Installation & Maintenance Manual



EVOLUTION-RO1000 Reverse Osmosis System Installation and Maintenance Manual

SAFETY GUIDES

Read and follow all steps and guides carefully before installing and using your reverse osmosis system. The included Quick Start Guide is only a basic guide to help you through the initial setup of the system. Please read this more detailed manual before running the system.

Do not use this product to make safe drinking water from non-potable water sources. Do not use the system on microbiologically unsafe water, or water of unknown quality without adequate disinfection before or after the system.

This reverse osmosis system contains replaceable components (membrane elements). These components are critical for the effective reduction of total dissolved solids and specific contaminants.

The Reverse Osmosis System does not have a monitoring device for contaminants. To verify that the system is performing satisfactorily the product water should be tested periodically by the system's installing dealer or a certified laboratory, every six months. The laboratory should be certified for testing the specific contaminants of concern. For a listing of certified laboratories, contact local regulatory agencies or Hydro-Logic. Within the United States, many state-run Department of Natural Resources or Department of Health Services maintain listings of certified laboratories.

The optional TDS Monitor can be used to monitor incoming tap water and outgoing purified water PPM (Parts Per Million) of TDS (total dissolved solids).

Consult your local public works department for plumbing and sanitation codes. Follow your local codes if they differ from this manual.

The reverse osmosis system works on water pressures of 40 psi (2.8 bar) minimum to 80 psi (5.5 bar) maximum. Water pressure can be reduced by installing a pressure reducing valve in the water supply pipe to the RO system. A booster pump should be used for low pressure applications. Both are available through your dealer or Hydro-Logic.

Do not install the reverse osmosis system in extreme hot or cold temperatures. Temperature of the water supply to the reverse osmosis system must be between 40°F (4°C) and 100°F (38°C).

Do not install on hot water lines.

The reverse osmosis membranes contain a foodgrade preservative for storage and shipment. All new membranes require a minimum 2 hour rinse to properly rinse out the preservative. The preservative is not harmful but makes the product water taste objectionable. Rinsing the membrane also acts as a performance conditioner. All new membranes will reach their stable maximum performance after 8 hours of rinsing.

THE BASIC REVERSE OSMOSIS SYSTEM

Your Reverse Osmosis System is a water treatment unit. It uses water pressure to reverse a natural physical process called osmosis. Water, under pressure, is forced through a semi-permeable membrane to filter out minerals and impurities. Treated drinking water goes through the blue line. Minerals and impurities are sent to the drain with RO waste water through the black line.

The system includes a replaceable carbon pre-filter and 2 membrane elements. The pre-filter reduces sand, silt, dirt, rust particles, other sediments, chlorine, chloramines, iron and sulfur from the incoming water supply before they enter the RO membrane elements. An optional high capacity pre-filter, the Pre-Evolution, is available to add 2 extra stages of pre-filtration. This will help further reduce the contaminants listed above as well as cut down on filter changes and maintenance of the Evolution-RO1000. An optional De-Ionization post-filter will remove any remaining PPM of TDS in the water after passing through the RO system.

BEFORE INSTALLING THE RO SYSTEM

- Best performance of the system will be achieved when the incoming water has been pre-treated.
- The water coming into the system must be within certain limits for sediments, pressure, etc. Refer to the specifications to determine if your installation is within the limits.
- A water quality analysis can be performed to determine if incoming water requires any treatment. Contact your dealer/installer or Hydro-Logic.
- The filters and membrane elements in the RO system need to be replaced on a regular basis. Follow the instructions for replacement that are in this manual.

NOTE: For optimal system performance, use the system for at least 2 minutes continuously each day.

⚠ WARNING: The RO system is designed to work without the aid of a pressurized storage tank. Installation of a pressurized storage tank will negatively affect system performance. You can, however, store the purified water in non-pressurized storage tank or reservoir. Using the optional 3/8" Float Valve will ensure you do not flood your working area.

NOTE: High levels of certain contaminants in the incoming water may prematurely foul the membranes and/or the pre-filter. A water softener or other forms of pre-filtration may be necessary. Contact Hydro-Logic for options.

THE BASIC REVERSE OSMOSIS SYSTEM cont.

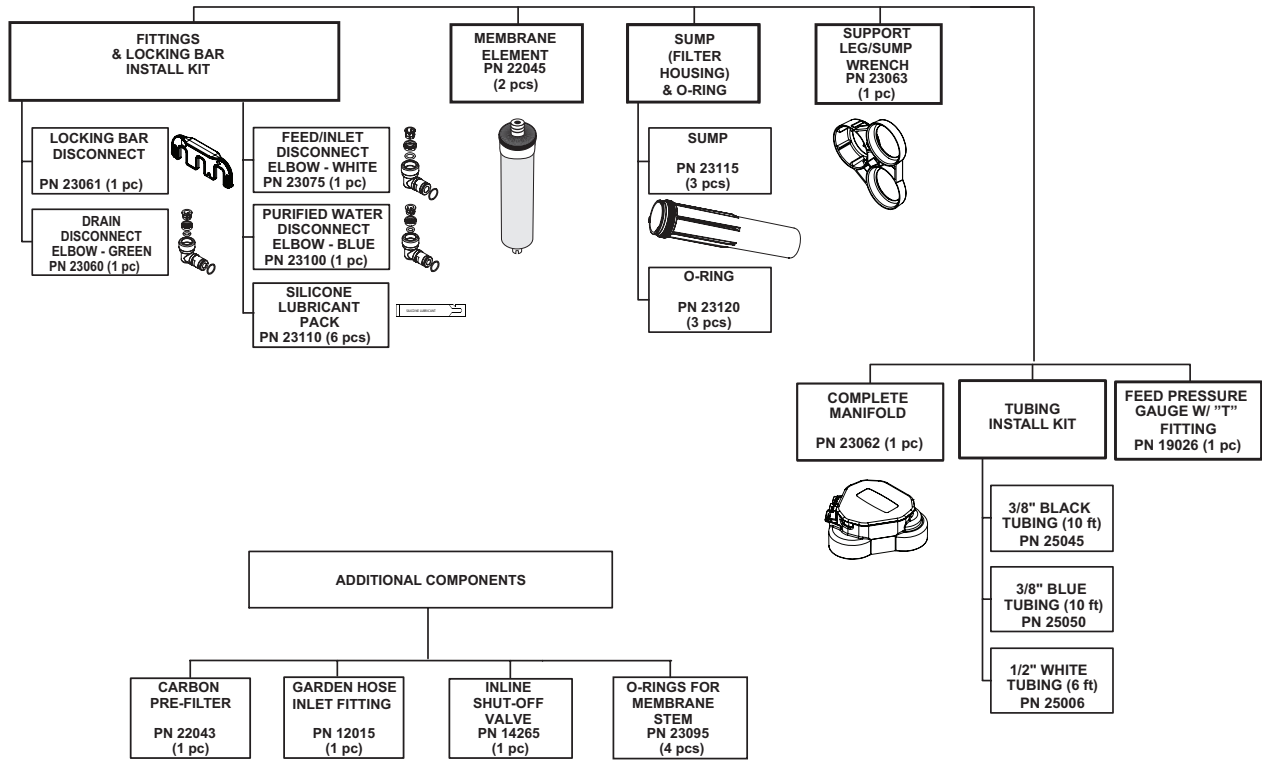

Note: For use with chlorinated (city) and non-chlorinated (well) water supplies.

THE BASIC REVERSE OSMOSIS SYSTEM cont.

LOCATION OF SYSTEM

The reverse osmosis system can be installed under or near a sink or any other water supply. The RO assembly can be placed on the sink cabinet floor in any other location that does not apply pressure on the disconnect elbows or tubing. A nearby suitable drain point is also required for the drain (waste) water.

NOTE: Keep the lengths of tubing short. Longer lengths of tubing will decrease inlet pressure and ultimately system performance. An optional booster pump can be used on the supply line to increase inlet pressure.

NOTE: All plumbing should be done in accordance with state and local plumbing codes.

Some codes may require installation by a licensed plumber. Check with the local plumbing authority prior to installation.

⚠ WARNING: All components and tubing should be located in an area which is not exposed to freezing temperatures. Do not expose unit or tubing to direct sunlight.

Water Supply: To provide supply water to the RO system inlet, a garden hose connection fitting is included with the system. Other types of feed supply fittings are available to allow hookup to a variety of feed sources. The feed water valve should be located as close to the manifold assembly as possible. **USE A POTABLE COLD WATER SUPPLY ONLY.** Softened water is preferred as it will extend the life of the RO membrane elements. Other forms of pre-filtration may be necessary depending on quality of incoming water.

Drain Point: A suitable drain point is needed for reject (waste) water from the RO system. A floor drain, laundry tub, standpipe, sump, etc. are all acceptable. If discharging into the utility sink or standpipe, an air gap of greater than 1/2-inches above the flood rim must be provided.

An optional 3/8" quick connect sink p-trap drain adapter is available to install as an optional drain point where codes permit.

Do not connect the system drain line to the dishwasher drain or near the garbage disposal. Back pressure from these units may cause the air gap to overflow.

RO Manifold Assembly: The RO system can be installed in either a horizontal or vertical orientation. Installation in the basement is also an option. One possible location is near the laundry/ utility sink where cold potable water and drain access are close. The location chosen should allow adequate clearance and accessibility for membrane element changes.

THE BASIC REVERSE OSMOSIS SYSTEM cont.

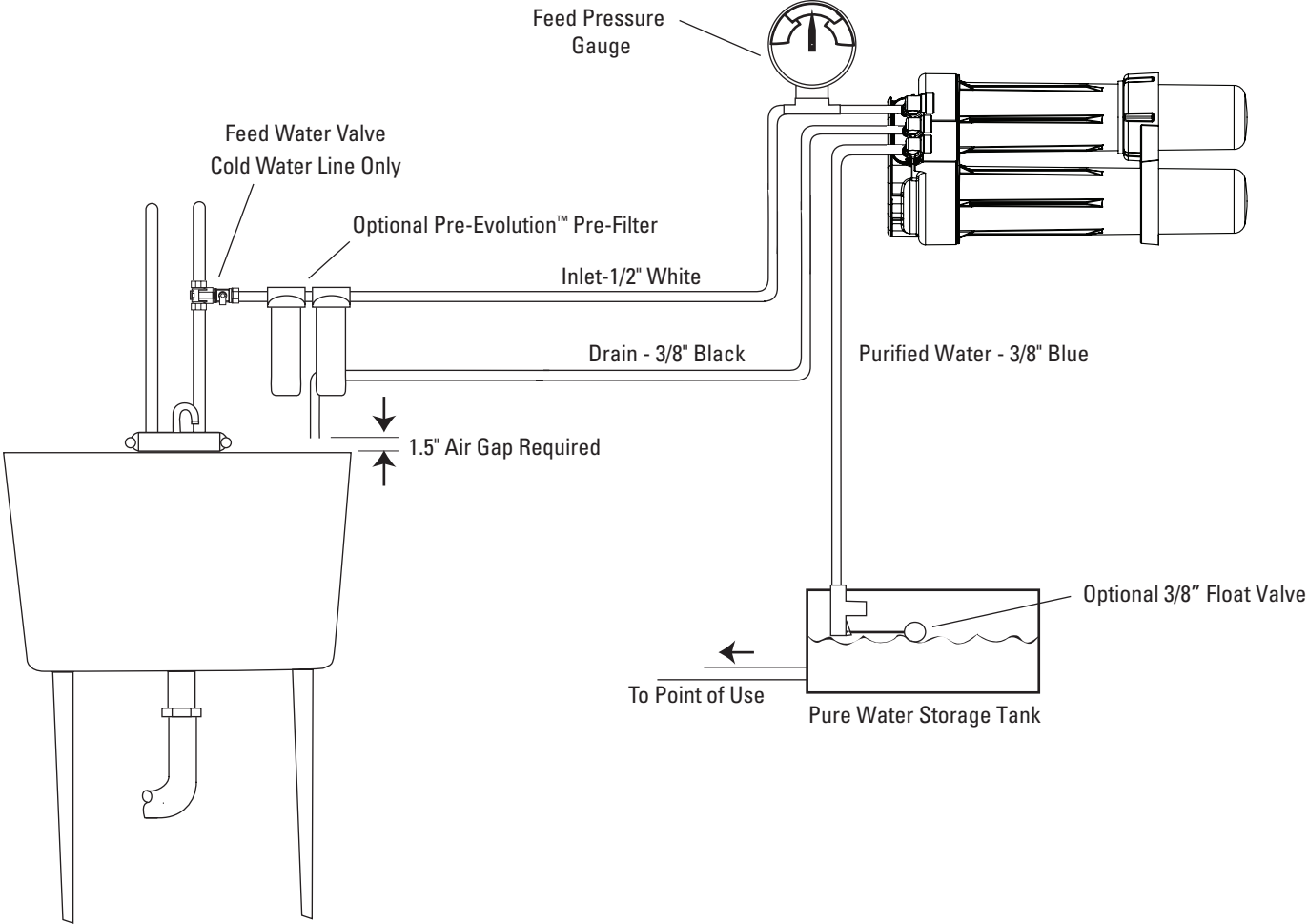

Typical Light Commercial Installation with Storage Tank

INSTALLATION

STEP 1: Install cold water supply fitting. Use either the included garden hose connector or any of the other optional feed fittings.

STEP 2: Install optional drain adapter

STEP 3: Make tubing connections

STEP 4: Install RO assembly

STEP 5: Put system into operation

NOTE: Consult a licensed plumber if you are not familiar with plumbing procedures.

Step 1: Install Cold Water Supply Fitting

A female garden hose thread connector fitting is included to be able to hook up to a garden hose or hose bib (spigot). Keep the length of garden hose as short as possible to minimize pressure loss. A variety of other feed fitting and feed valves are available to be able to connect to other existing plumbing. Check with your dealer or contact Hydro-Logic. Comply with local plumbing codes.

WATER SUPPLY VALVE

NOTE: Be sure to turn off the water supply before installation

Cold water pipes vary in size and style. The installer will determine type of valve that will be used. Install a valve on the cold water supply pipe to adapt 1/2-inch OD tubing. If threaded fittings are used, be sure to use pipe joint compound or Teflon tape on outside threads. Turn the valve off.

Step 2: Direct black drain line to an appropriate drain location or install optional drain adapter.

The optional 3/8" quick connect drain adapter must be installed on the main sink drain above the P-trap. The drain adapter is designed to fit 1-1/2-inch (3.8 cm) sink drain pipe. The black drain line may also be directed directly into a drain point or outside. The drain water can be re-used for a variety of applications including watering your landscape plants, trees, shrubs and lawns. The drain (waste) water contains the majority of the contaminants in your source (tap) water. The PPM's of the drain water are typically 33% higher than the source water. A certain amount of drain water is necessary to flush the contaminants away from the membranes and prevent them from fouling or scaling prematurely. DO NOT restrict the black drain line. Let it flow freely.

INSTALLATION cont.

Step 3: Make Tubing Connections

The connections to the faucet should be complete, the remaining connections are:

- Feed connection—white 1/2" tubing from feed fitting or feed valve to pressure gauge and then to white elbow connector
- Drain connection—black 3/8" tubing from green elbow connection will attach to the optional drain adapter or be directed to appropriate drain location
- Purified water connection—blue 3/8" tubing blue elbow connection to reservoir or tank via optional 3/8" float valve
- Attach the fittings to the manifold

A typical connection is shown in Figure 7 Side View and Cutaway of Tubing Fitting.

NOTE: For optimal system performance, we recommend using tubing lengths that are as short as possible.

Feed Pressure Gauge w/ "T" fitting

The supplied pressure gauge should be connected to the feed line to monitor system feed pressure. For proper system performance, the inlet feed pressure must be between 40 psi (2.76 bar) and 80 psi (5.52 bar) when the system is in operation. Insert the short length of tubing into the white elbow connector. Then install pressure gauge w/ "T" fitting. Then install long length of white tubing to other end of pressure gauge "T" fitting.

Inline Shut-off Valve

The supplied 3/8" inline shut-off valve is designed to be installed on the blue pure water line. The system can be shut-off by using this valve.

Step 4: Install RO Assembly

The RO Assembly includes the following components: sumps (3), support leg, carbon pre-filter, and RO membrane elements (2). The tubing is attached to the manifold by the elbow connectors. When choosing a location for the system, allow enough tubing for it to be moved for periodic servicing of the pre-filter and membrane elements (Figure 8 RO Assembly).

⚠ WARNING: Do not attempt to mount/hang the system. Do not try to drill mounting holes anywhere on the system. If putting above ground/cabinet level, a sturdy, permanent shelf is recommended.

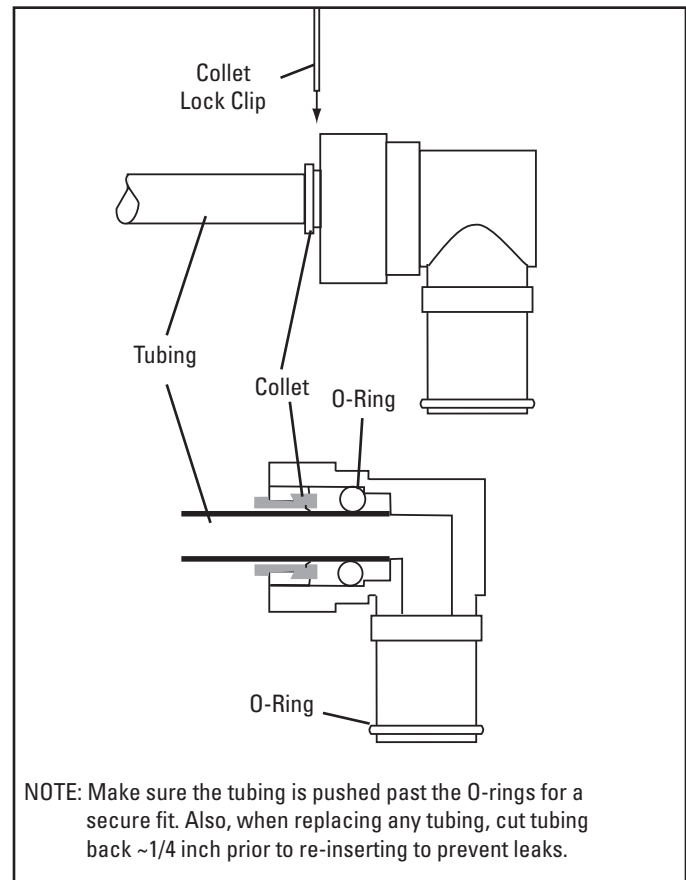

Figure 1 Side View and Cutaway of Tubing Fitting

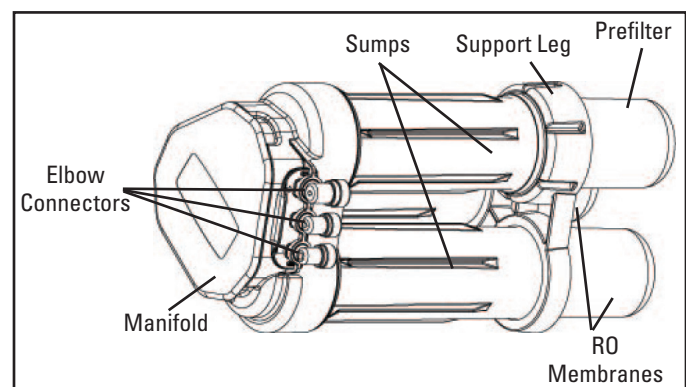

Figure 2 RO Assembly

INSTALLATION cont.

Recommended Placement Positions

The RO assembly should be positioned in one of two ways.

The first position is with the unit standing upright using the support leg with the sumps horizontal. The tubing is directed to provide the best fit.

The second position, sets the unit on end so the sumps are pointing up. The tubing is directed upward and the locking bar is down to lock the tubing connections. See Figure 9 System Positions.

NOTE: Ensure that the support leg is installed on the sumps.

Connection Lubrication

Connections with O-rings must be properly lubricated. The following instructions describe the method and locations for lubrication.

Six packets of silicone lube are supplied. One packet should be completely used to lubricate the O-ring contact surfaces in the 3 manifold ports and 2 RO membrane locations (Figure 10). Follow Figure 11 and lubricate the filter seat and the flat surface below the threads for the 3 sump locations. Use a complete packet of silicone for each sump location.

NOTE: To properly lubricate the O-ring contact area, a film of clean silicone grease is applied. The film should cover all of the surface area that the O-ring will slide over and seal with. Do not use grease containing petroleum products.

NOTE: The Quick Start guide indicates applying the lube directly to the O-rings as opposed to the contact surfaces of the O-rings. Either method is appropriate.

NOTE: Please save extra lube packs for future membrane changes. Extra lube packs can be sourced through your dealer, Hydro-Logic, plumbing supply stores, or hardware stores.

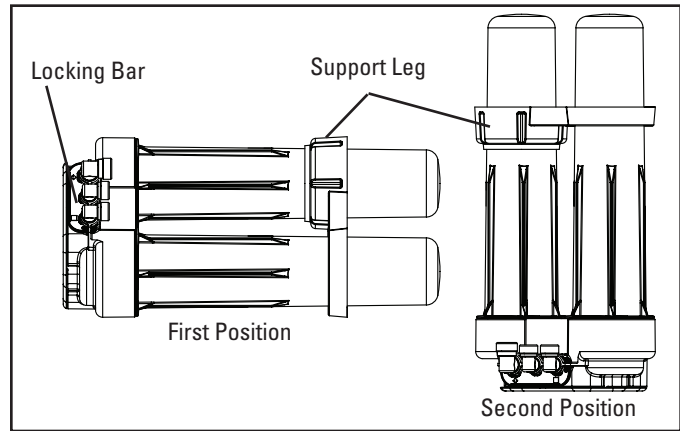

Figure 3 System Positions

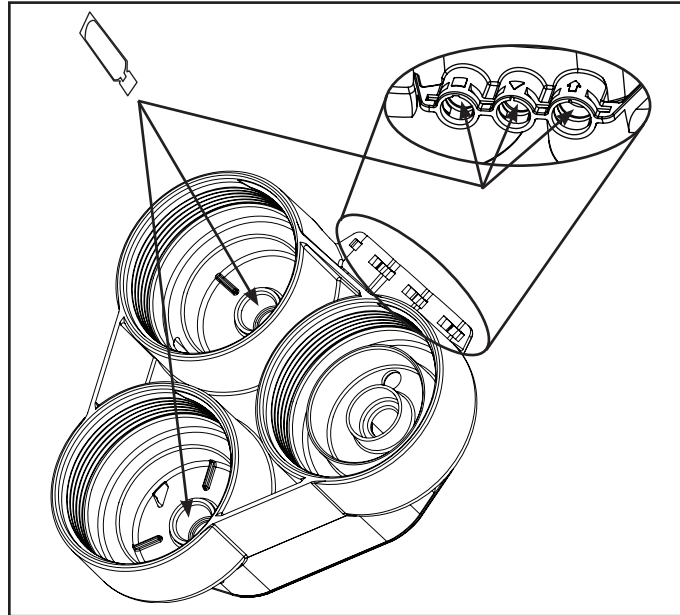

Figure 5

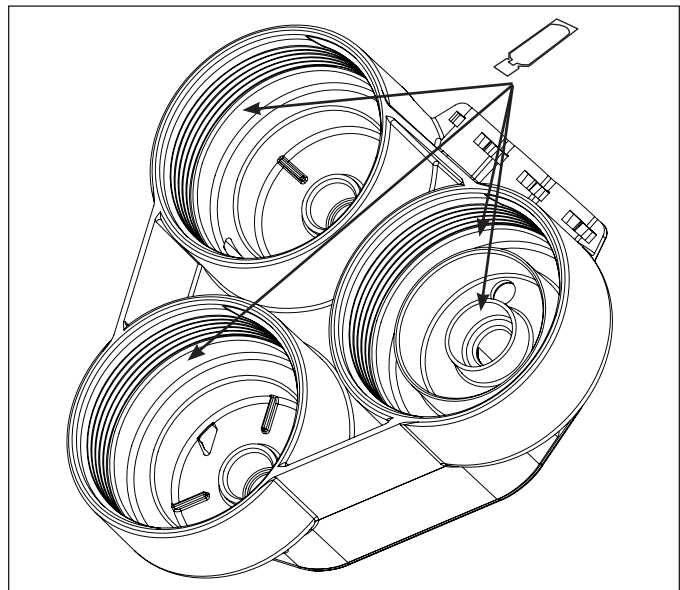

Figure 4

INSTALLATION cont.

The table below shows the coding system for the fitting connections. Each fitting has a unique “keyed” socket on the manifold. Each fitting also has a graphic symbol molded into the elbow with a corresponding symbol on the manifold.

| Connector Symbol | Connection | Tubing Color |
|------------------|-------------|--------------|
| ↔ | Feed-Inlet | Natural |
| — | Concentrate | Black |
| □ | Product | Blue |

⚠ WARNING: Be sure to lubricate the manifold ports with silicone lubricant, prior to inserting the fittings into manifold.

⚠ WARNING: Do not turn the incoming water valve on until the locking bar is in place.

When all of the connections have been made, use the locking bar to hold the fittings in position. Match the symbols on the locking bar to the corresponding symbols on the manifold (Figure 12).

Step 6: System Startup

1. Inspect all connections.
2. Position manifold horizontal with openings facing up.
3. Remove new membrane elements from plastic packaging. The blue and green tape surrounding the membrane are an important part of the membrane element and should not be removed.

CAUTION: Elements contain a foodgrade preservative. The use of sterile/latex gloves is recommended.

4. Lubricate all O-ring seats in the manifold that come in contact with the sump and element O-rings. Refer to "Connection Lubrication" on page 8.

NOTE: To properly lubricate the O-ring contact area, a film of clean silicone grease is applied. The film should cover all of the surface area that the O-ring will slide over and seal with. Do not use grease containing petroleum products.

5. Securely insert O-ring end of membrane elements into manifold. Push the membrane straight down into the hole in the manifold. Do not twist or rock the membrane when installing, as this may damage the o-rings.
6. Remove pre-filter from packaging. Check that gaskets are in place.
7. Place pre-filter in manifold.
8. Replace sumps and tighten until it bottoms out. (DO NOT OVERTIGHTEN)

Pressure Test System

To check for leaks, the system must be filled with water and brought up to operating pressure.

1. Open cold water feed valve slowly. Run at 1/2 open for a minute, then open fully.
2. Make sure included shut off valve installed on the blue purified water line is in the open position.
3. Check for leaks.

NOTE: When the system is initially turned on, water may temporarily sputter all the air is purged. Allow 1 to 3 hours for any trapped air noise in the system to subside.

4. Purge the system. Run the water through the RO system allowing all water to go to drain for two to eight hours to stabilize the pH and PPM's of the purified water

NOTE: A minimum of a 2 hour flush is required to remove the food grade preservative. After 8 hours performance will reach its stable maximum performance.

The RO system is now ready for use.

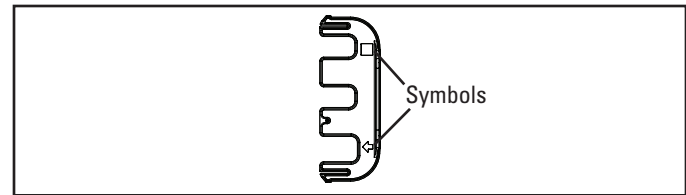

Figure 6

EvolutionRO1000™ | Expected Flow Rates

| Inlet Pressure | Gallons Per Day | Waste to Purified Water Ratio |
|----------------|-----------------|-------------------------------|
| 40 psi | 700 | 2.5:1 |
| 50 psi | 900 | 2.3:1 |
| 60 psi | 1100 | 2:1 |
| 70 psi | 1300 | 1.8:1 |
| 80 psi | 1500 | 1.7:1 |

Tested @ 77F and 500 PPM source water. Flow rates will vary depending on source water, temperature and PPM's

NOTE: The flow rate of purified water will vary depending on 3 factors:

- Inlet water pressure
- Inlet water temperature
- Inlet water PPM

TO CARE FOR THE RO SYSTEM

The components of the RO system are designed to function with minimal maintenance. However, the membrane elements and pre-filter will need to be replaced on a regular schedule.

For optimal performance the system should be flushed for 2 minutes if periods of inactivity that extend past six hours.

REPLACEMENT OF PRE-FILTER

The carbon pre-filter reduces sediment and certain chemicals, such as chlorine, from the water. Depending on water use and the amount of impurities, this filter should be replaced a minimum of 2,000 gallons of purified water produced.

Applications using more than an average of 20 gallons purified water per day should install the optional Pre-Evolution high capacity pre-filter to further reduce chlorine, sediment, and other contaminants.

REPLACEMENT OF RO MEMBRANE ELEMENTS

The functional life of the RO membrane elements will vary based on feed water quality. Product water should be tested periodically to verify the membrane elements are performing properly. For most applications, the RO membrane elements should be replaced every 6 months to two years.

NOTE: Softened water is recommended for optimal system performance and RO membrane element life.

| REPLACEMENT & UPGRADE FILTERS | | | | | | | | | | |
|---|-------------------|-----------------------------------|-----------------------|------------------|---------------------|-------------------------|------------------|------------------|----------------|----------------|
| Part Description | HydroLogic Part # | Filter Replacement Schedule | Reduces PPM (by 95%+) | Reduces Chlorine | Reduces Chloramines | Reduces Sediment & Dirt | Reduces Iron | Reduces Sulfur | For Well Water | For City Water |
| Evolution-RO1000™ KDF/Carbon Pre-Filter | 22043 | 2,000 Gallons | N | Y | Y | Y | Low Levels | Low Levels | Y | Y |
| Evolution-RO1000™ Membrane Element | 22045 | 6 Months - 2 Years | Y | N | N | N | Low Levels | Low Levels | Y | Y |
| Pre-Evolution™ KDF/Carbon Filter - 10"x4.5" | 22096 | 7,500 Gallons | N | Y | Y | N | Low - Med Levels | Low - Med Levels | Y | Y |
| Pre-Evolution™ Sediment Filter - 10"x4.5" | 22097 | Clean regularly - Change annually | N | N | N | Y | N | N | Y | Y |

REPLACEMENT OF THE PRE-FILTER, AND RO MEMBRANE ELEMENTS

1. Turn off the water supply to the RO System.
2. Reduce system water pressure by opening the included shut off valve or optional float valve.

CAUTION: Even with the water supply turned off the membrane and pre-filter sumps will contain a considerable amount of water. By positioning the RO assembly in a sink or tub, most of the water will be contained.

3. Disconnect locking bar and place the fittings (with tubing still connected) into a tub or bucket.
4. Move system into a contained area, such as a sink or tub.
5. Remove the support leg from the three sumps and unscrew the top sump as shown to access the pre-filter. The support leg functions as a wrench to loosen the sump, Figure 13.

NOTE: There is no need to disconnect tubing from fittings on the manifold. Remove locking bar and pull fittings out. Lubricate O-rings with silicone prior to re-assembly.

NOTE: If changing only the pre-filter the other sumps do not need to be removed. If changing the membrane elements, the pre-filter should also be changed.

6. Remove exhausted pre-filter and discard.

CAUTION: The person handling the filters and membrane elements must have clean hands to keep the system sanitized. The use of sterile/latex gloves is recommended.

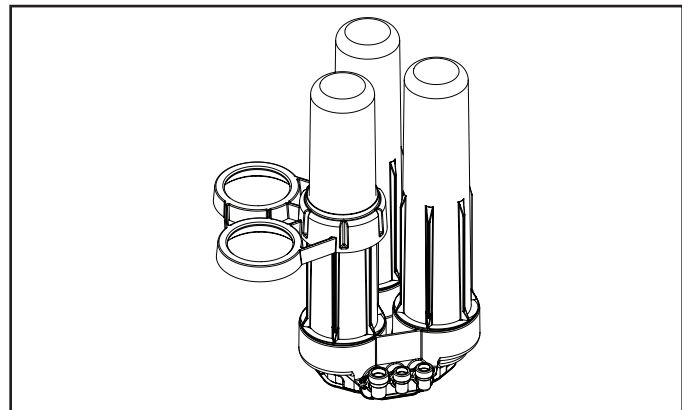

Figure 7

REPLACEMENT OF THE PRE-FILTER, AND RO MEMBRANE ELEMENTS cont.

7. If changing membrane elements:
 - a. Remove membrane sumps. Remove and discard used elements.
 - b. Remove new elements from packaging.
- CAUTION:** Elements contain a foodgrade preservative. The use of sterile/latex gloves is highly recommended.
- c. Lubricate element O-rings, brine seals, and sump O-rings with silicone lubricant. Refer to "Connection Lubrication" on page 8 for correct lubrication procedure of elements cartridge.
 - d. Securely insert O-ring end of elements into manifold. See Figure 13.
 - e. Replace sumps and tighten until it bottoms out.

NOTE: The system should be sanitized whenever a membrane element or filter is replaced.

8. Sanitize the system.
 - a. The manifold should be positioned flat with the sump connections facing up.
 - b. Pour a tablespoon (15 milliliters) of chlorine bleach into the center opening of the prefilter sump connection. See Figure 14.
9. Install pre-filter.
 - a. Remove new prefilter from packaging. Ensure gaskets are secure. Insert prefilter into proper opening on manifold.
 - b. Lubricate sump O-ring with silicone lubricant.
 - c. With the pre-filter element in place, screw the sump into the connection. Tighten until it bottoms out.
10. Re-connect the fittings to the manifold and lock in position with locking bar.
11. Re-position the assembly and turn the water supply on. Check the system for any leaks.

CAUTION: Water may sputter from the air gap until the trapped air is purged.

12. Open the shut off valve or float valve and run water for two minutes.
13. Shut off the shut off valve or float valve and allow the system to stand idle for 20 to 30 minutes.
14. Open the shut off valve or float valve and run water for five minutes.
15. Check for any system leaks.

NOTE: If the two RO membrane elements were replaced the system must be flushed according to Step 6 the system startup procedure as stated above.

The RO system is now ready for use.

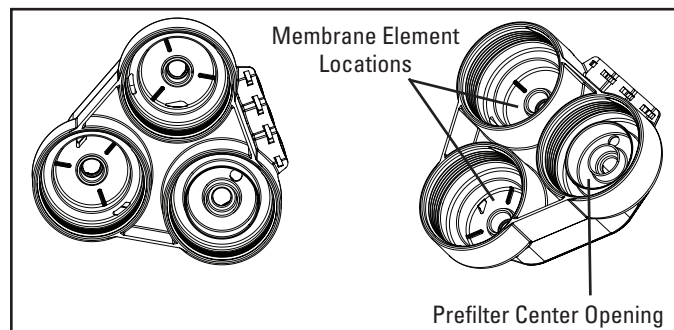

Figure 8

NOTE: For long-term storage of the unit you must store both membranes in a sealed plastic bag in the refrigerator. Do not let the membranes dry out. It is OK to store the carbon pre-filter dry.

Performance Specifications

Minimum and Maximum Operating Conditions

| Condition | Minimum | Maximum |
|-------------------|-------------------|---------------------|
| Inlet Pressure | 40 psi (2.76 bar) | 80 psi (5.52 bar) |
| Inlet Temperature | 40°F (4.44°C) | 100°F (37.78°C) |
| Inlet TDS | 50 mg/L | 2,000 mg/L |
| Inlet Hardness | 0 mg/L (0 grain) | 171 mg/L (10 grain) |
| Inlet Chlorine | 0 mg/L | 1.0 mg/L |
| Inlet Iron | 0 mg/L | 0.1 mg/L |
| Inlet Manganese | 0 mg/L | 0.05 mg/L |
| Inlet pH | 4 | 10 |
| Inlet Turbidity | 0 | 1 NTU |

Dimensions

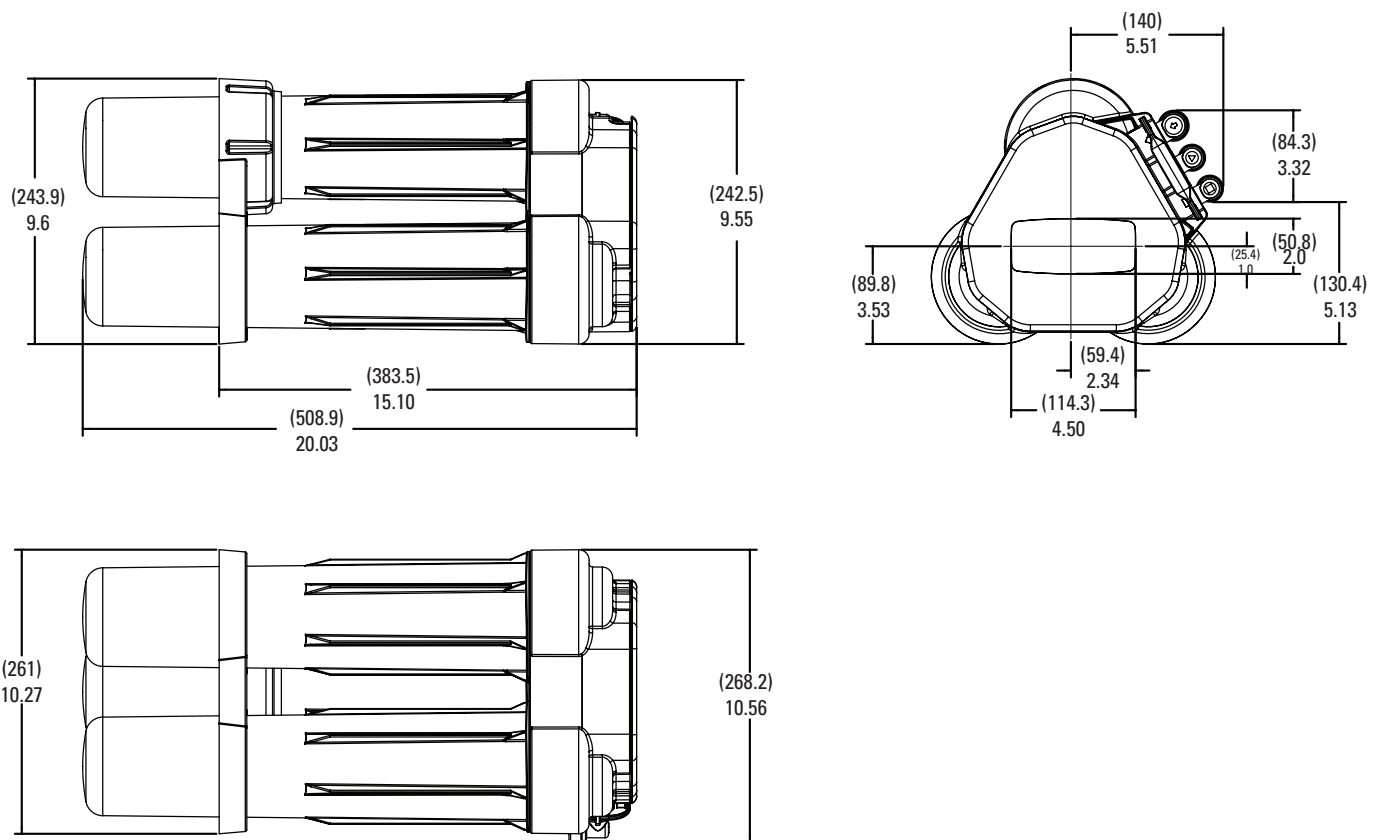
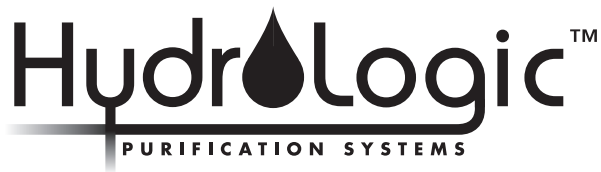

Figure 9

TROUBLESHOOTING

| Issue | Possible Cause | Corrective Action |
|---|---|--|
| Low product flow rate | Low driving pressure. | Increase feed pressure. Consider pump for low pressure locations. Use short tubing runs to decrease flow restriction. Increase tubing diameter for longer distances. |
| | Low water temperature or high total dissolved solids (TDS). | Increase feed water temperature or feed pressure to compensate. |
| | Plugged prefilter. | Replace plugged prefilter. Consider sediment prefilter for non-chlorinated applications. |
| | Scaled or fouled RO membrane. | Replace membranes. |
| | Leak or kink in product line. | Find and repair leak or kink. |
| Concentrate water runs to drain after faucet shut off | Plugged prefilter | Replace plugged prefilter. Consider sediment prefilter for non-chlorinated applications. |
| | Leak in product line. | Find and repair leak. Install pressure gauge in product line to help identify a product pressure leak. |
| Poor product water quality | Water sample taken during system flush. | Take sample after three minutes of continuous operation. |
| | Low driving pressure. | Increase feed pressure. Consider pump for low pressure locations. Use short tubing runs to decrease flow restriction. Increase tubing diameter for longer distances. |
| | Plugged pre-filter. | Replace plugged prefilter. Consider sediment prefilter for non-chlorinated applications. |
| | Scaled, fouled, or damaged RO membrane. | Replace RO membranes. |
| | Membrane stem o-rings damaged during installation | Replace both o-rings on membrane stem and lube properly before installing |



Hydro-Logic Purification Systems

370 Encinal Street, Suite 150
Santa Cruz, CA 95060

P: 888.426.5644

F: 831.336.9840

info@hydrologicsystems.com

www.hydrologicsystems.com

For available options and add-ons,
contact Hydro-Logic directly

